

PMS Centrifugal pumps

Technical data

- Delivery rate
 $Q_{\max} = 400 \text{ l/min}$
- Delivery head
 $H_{\max} = 45 \text{ m}$
- Delivery temperature
 $T = 0^{\circ}\text{C bis } +80^{\circ}\text{C}$
- Kinematic viscosity
 $\nu_{\max} = 20 \text{ mm}^2/\text{s}$



PMS 05, 06, 08, 10 – Immersion pumps, sealless 50 Hz, open impellers



Features

- Vertical multistage pump
- Connecting dimensions according to DIN EN 12157
- For delivery of slightly contaminated types of fluids
- Installation directly into the reservoir
- Pressure port is located above the reservoir plate and designed with internal thread G3/4
- Unventilated motor

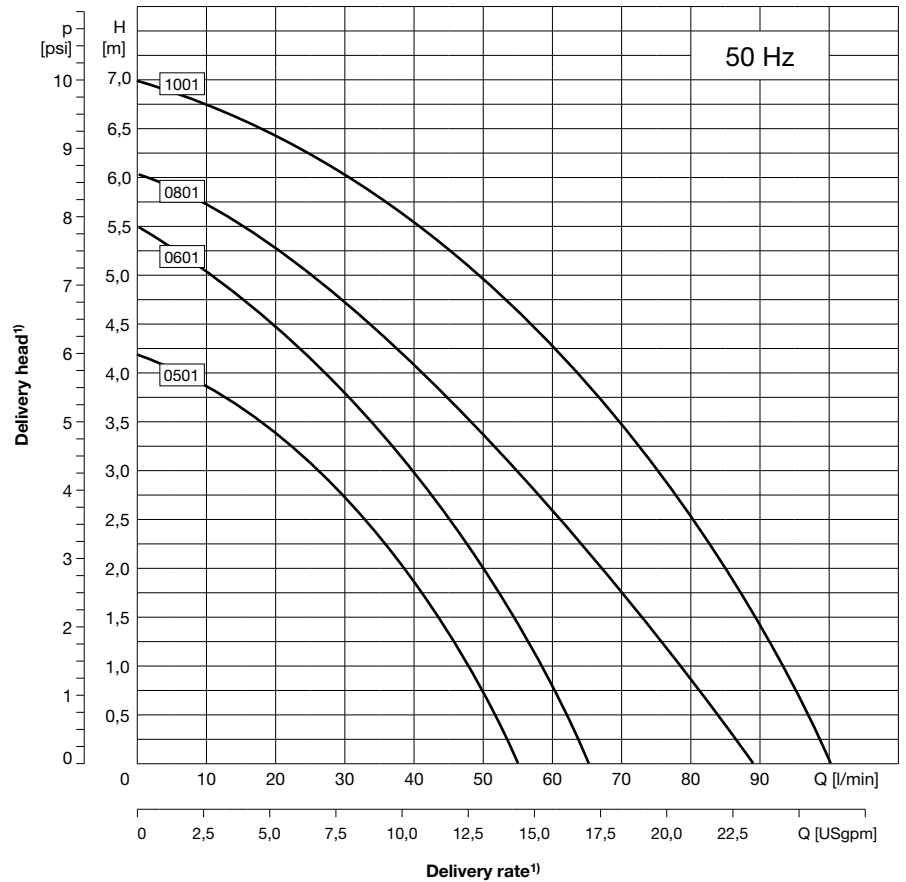

Technical data

Delivery rate Q_{max}	100 l/min
Delivery head H_{max}	7 m
Immersion depth t_{max}	350 mm
Kinematic viscosity	max. 20 mm ² /s
Delivery temperature	
Material "P"	0 °C to 60 °C
Material "G"	0 °C to 80 °C
Grain size	max. Ø5 mm
Contamination	max. 10 kg/m ³
Direction of rotation	anti-clockwise (as viewed looking down on the motor's ventilation side)
Fluids delivered	Various industrial use fluids, emulsions, also with chemical additives, oils, water with corrosion protection additive, water colors, heat transfer oils

Mechanical design

Component	Material
Flange	EN-GJL-200 and steel
Shaft	1.0762
Impeller	POM
Intermediate chamber	EN-GJL-200
Bushes	PTFE graphite
Pumps bottom material "P"	POM
Splash ring material "P"	NBR

Variations

Component	Material
Bottom with extension tube "V"	EN-GJL-200
Impeller material "G"	EN-GJL-200
Bottom standard design "G"	EN-GJL-200
Splash ring material "G"	1.0718

¹⁾ Data for viscosity of ~1 mm²/s at a density of ~1 kg/dm³. Minimum volumetric flow: 5 to 10 % of nominal delivery rate.

PMS 05, 06, 08, 10 – Immersion pumps, sealless 50 Hz, open impellers

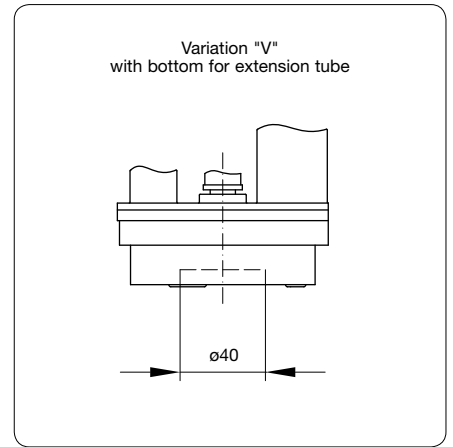
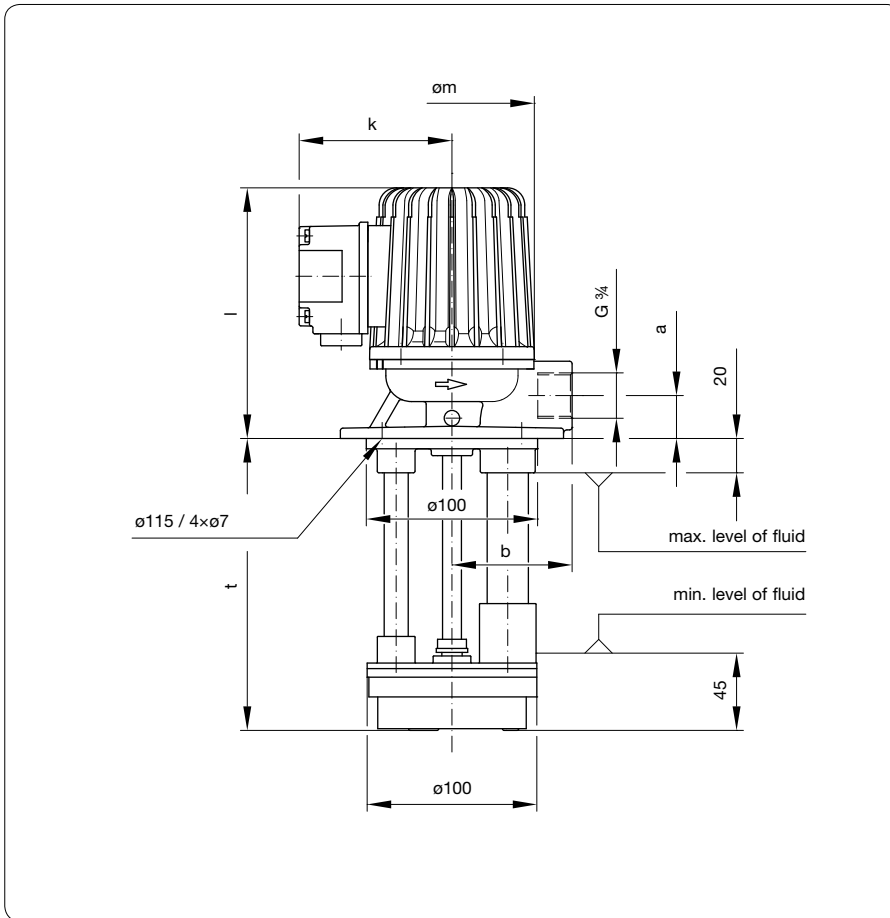

Electrical data, dimensions and weights at 50 Hz

Type of pump			Immer- sion depth t [mm]	Rated motor values					Dimensions [mm]					Weight [kg]	Sonic pressure [dBA]	Pressure port (DIN ISO 228)
Series	Frame size	Stages		Voltage Δ/Y U [V]	Motor index	Output P_N [kW]	Current Δ/Y I_N [A]	Speed n_N [min ⁻¹]	$\varnothing m$	k	l	$\varnothing a$	b			
PMS	05	01	90	230/400	A	0,09	0,46/0,26	2618	96	89	146	25	70	4,4 – 5,0	46	G $\frac{3}{4}$
			120													
			140													
			170													
			200													
			220													
	250															
	270															
	350															
	06	01	90	230/400	A	0,09	0,46/0,26	2618	96	89	146	25	70	4,4 – 5,0	46	
			120													
			140													
			170													
			200													
			220													
	250															
270																
350																
08	01	120	230/400	B	0,12	0,50/0,29	2655	96	89	168	25	70	4,4 – 5,0	55		
		170														
		220														
		250														
10	01	90	230/400	C	0,18	0,83/0,48	2788	120	99	160	25	70	6,3 – 7,3	55		
		120														
		140														
		170														
		200														
		220														
250																
270																
350																

PMS 05, 06, 08, 10 – Immersion pumps, sealless 60 Hz, open impellers



Merkmale

- Vertical multistage pump
- Connecting dimensions according to DIN EN 12157
- For delivery of slightly contaminated types of fluids
- Installation directly into the reservoir
- Pressure port is located above the reservoir plate and designed with internal thread G3/4
- Unventilated motor

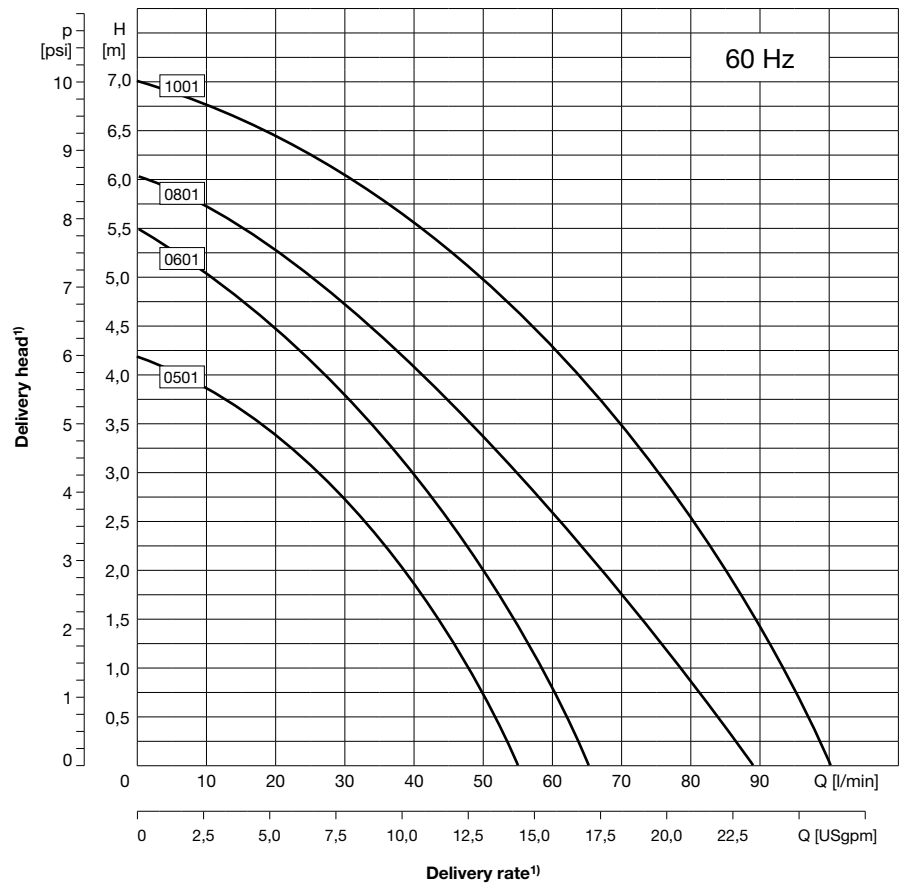

Technical data

Delivery rate Q_{max}	100 l/min
Delivery head H_{max}	7 m
Immersion depth t_{max}	350 mm
Kinematic viscosity	max. 20 mm ² /s
Delivery temperature	
Material "P"	0 °C bis 60 °C
Material "G"	0 °C bis 80 °C
Grain size	max. Ø5 mm
Contamination	max. 10 kg/m ³
Direction of rotation	anti-clockwise (as viewed looking down on the motor's ventilation side)
Fluids delivered	Various industrial use fluids, emulsions, also with chemical additives, oils, water with corrosion protection additive, water colors, heat transfer oils

Mechanical design

Component	Material
Flange	EN-GJL-200 and steel
Shaft	1.0762
Impeller	POM
Intermediate chamber	EN-GJL-200
Bushes	PTFE graphite
Pumps bottom material "P"	POM
Splash ring material "P"	NBR

Variations

Component	Material
Bottom with extension tube "V"	EN-GJL-200
Impeller material "G"	EN-GJL-200
Bottom standard design "G"	EN-GJL-200
Splash ring material "G"	1.0718

¹⁾ Data for viscosity of ~1 mm²/s at a density of ~1 kg/dm³. Minimum volumetric flow: 5 to 10 % of nominal delivery rate.

PMS 05, 06, 08, 10 – Immersion pumps, sealless 60 Hz, open impellers

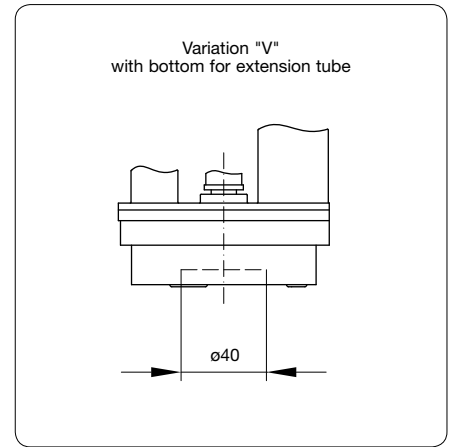
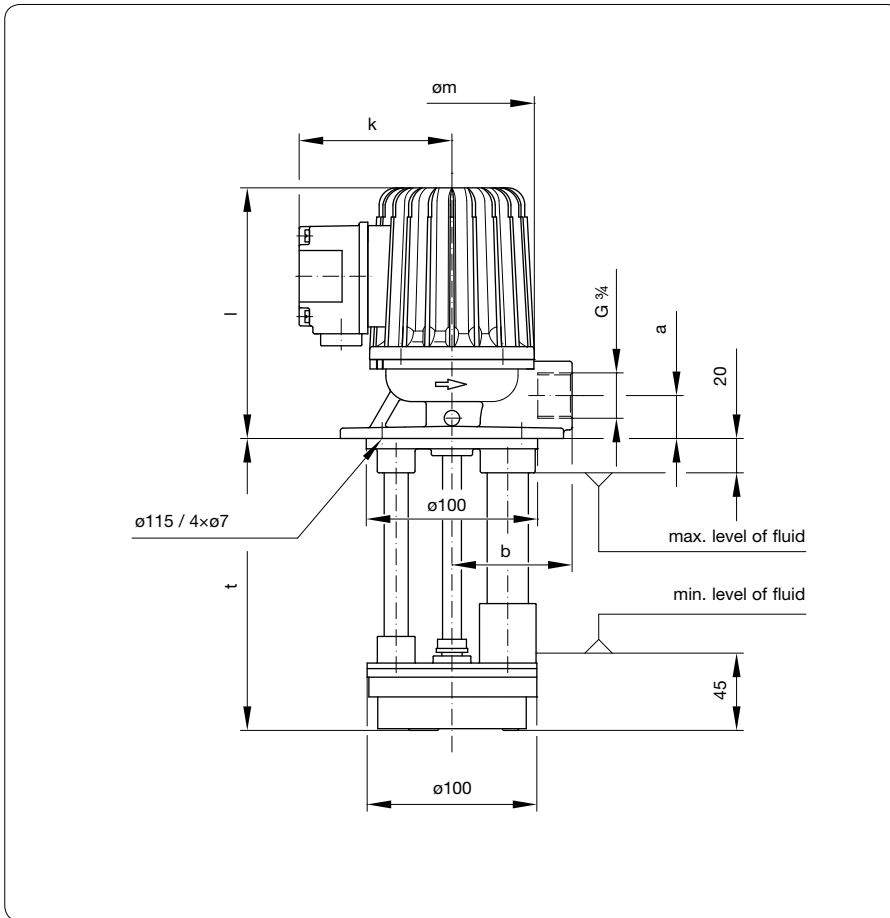

Electrical data, dimensions and weights at 60 Hz

Type of pump			Immer- sion depth t [mm]	Rated motor values				Dimensions [mm]					Weight [kg]	Sonic pressure [dBA]	Pressure port (DIN ISO 228)	
Series	Frame size	Stages		Voltage Δ/Y U [V]	Motor index	Output P_N [kW]	Current Δ/Y I_N [A]	Speed n_N [min ⁻¹]	$\varnothing m$	k	l	$\varnothing a$				b
PMS	05	01	90	265/460	A	0,09	0,46/0,26	3257	96	89	146	25	70	4,4 – 5,0	46	G $\frac{3}{4}$
			120													
			140													
			170													
			200													
			220													
	250															
	270															
	350															
	06	01	90	265/460	A	0,09	0,46/0,26	3257	96	89	146	25	70	4,4 – 5,0	46	
			120													
			140													
			170													
			200													
			220													
	250															
270																
350																
08	01	120	265/460	B	0,12	0,50/0,29	3320	96	89	168	25	70	4,4 – 5,0	55		
		170														
		220														
		250														
10	01	90	265/460	C	0,18	0,83/0,48	3437	120	99	160	25	70	6,3 – 7,3	55		
		120														
		140														
		170														
		200														
		220														
250																
270																
350																

PMS 25 – Immersion pumps, sealless 50 Hz, open impellers



Merkmale

- Vertical multistage pump
- Connecting dimensions according to DIN EN 12157
- For delivery of slightly contaminated types of fluids
- Installation directly into the reservoir
- Pressure port is located above the reservoir plate and designed with internal thread G1¼

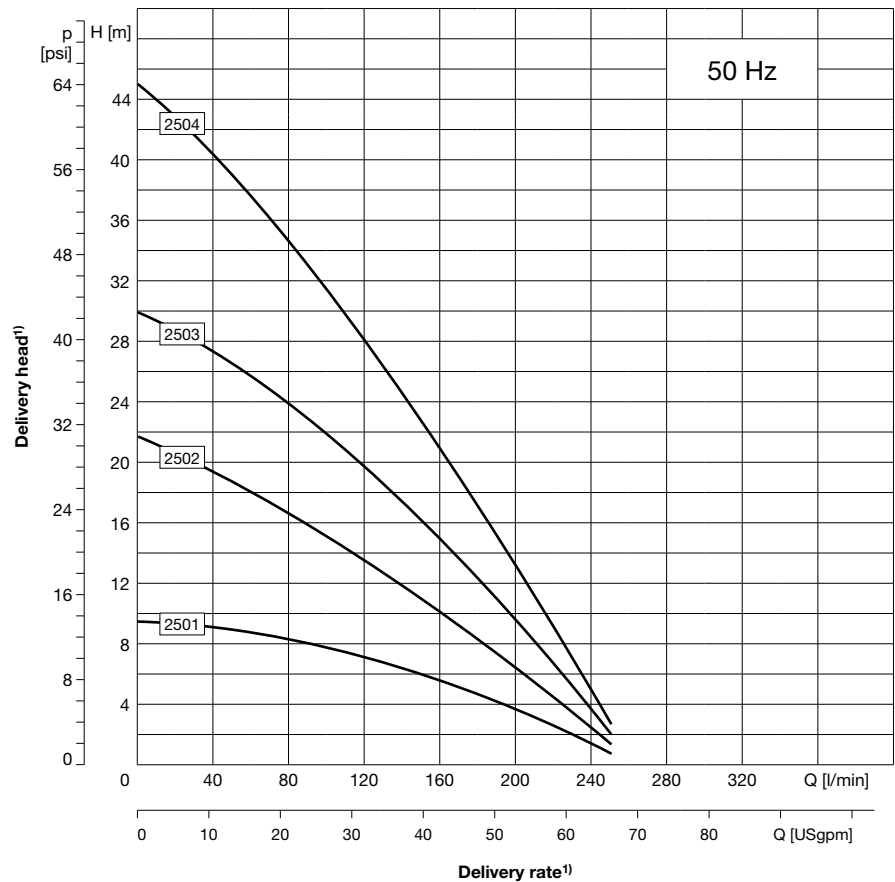

Technical data

Delivery rate Q_{max}	250 l/min
Delivery head H_{max}	45 m
Immersion depth t_{max}	550 mm
Kinematic viscosity	max. 20 mm ² /s
Delivery temperature	
Material "P"	0 °C bis 60 °C
Material "G"	0 °C bis 80 °C
Grain size	max. Ø8 mm
Contamination	max. 1,5% (proportion by weight)
Direction of rotation	anti-clockwise (as viewed looking down on the motor's ventilation side)
Fluids delivered	Various industrial use fluids, emulsions, also with chemical additives, oils, water with corrosion protection additive, water colors, heat transfer oils

Mechanical design

Component	Material
Flange	EN-GJL-200 and steel
Shaft	1.0762
Impeller	POM
Intermediate chamber	EN-GJL-200
Bushes	PTFE graphite
Pumps bottom material "P"	POM
Splash ring material "P"	NBR

Variations

Component	Material
Bottom with extension tube "V"	EN-GJL-200
Impeller material "G"	EN-GJL-200
Bottom standard design "G"	EN-GJL-200
Splash ring material "G"	1.0718

¹⁾ Data for viscosity of ~1 mm²/s at a density of ~1 kg/dm³. Minimum volumetric flow: 5 to 10 % of nominal delivery rate.

PMS 25 – Immersion pumps, sealless 50 Hz, open impellers

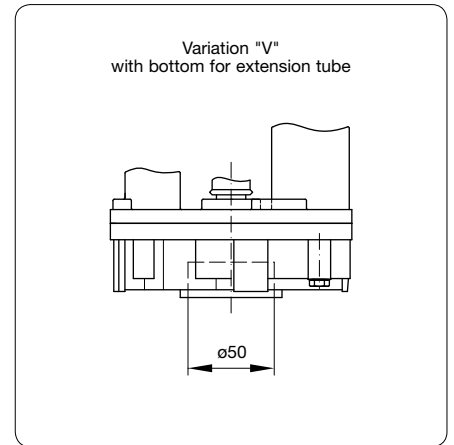
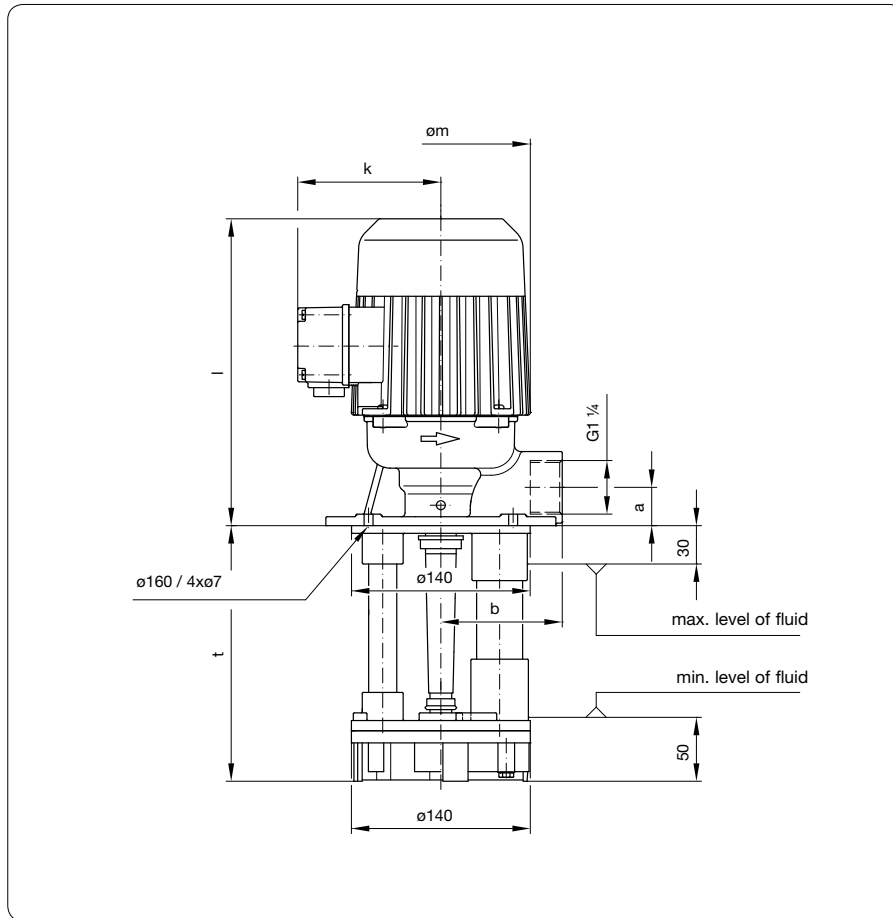

Electrical data, dimensions and weights at 50 Hz

Type of pump			Immer- sion depth t [mm]	Rated motor values				Dimensions [mm]					Weight [kg]	Sonic pressure [dBA]	Pressure port (DIN ISO 228)	
Series	Frame size	Stages		Voltage Δ/Y U [V]	Motor index	Output P _N [kW]	Current Δ/Y I _N [A]	Speed n _N [min ⁻¹]	Øm	k	l	Øa				b
PMS	25	01	170	230/400	F	0,55	2,06/1,19	2836	140	114	241	30	95	13,2 – 16,3	59	G1¼
			200													
			270													
			350													
			440													
		550														
		02	270	230/400	J	1,5	4,95/2,86	2850	176	149	332	32	100	24,0 – 27,5	59	
			310													
			350													
			390													
		03	480	230/400	J	1,5	4,95/2,86	2850	176	149	332	32	100	26,5 – 29,0	65	
			310													
			350													
04	390	230/400	L	3,0	10,0/5,75	2885	196	155	352	32	100	31,0	65			
	430															

PMS 25 – Immersion pumps, sealless 60 Hz, open impellers



Merkmale

- Vertical multistage pump
- Connecting dimensions according to DIN EN 12157
- For delivery of slightly contaminated types of fluids
- Installation directly into the reservoir
- Pressure port is located above the reservoir plate and designed with internal thread G1¼

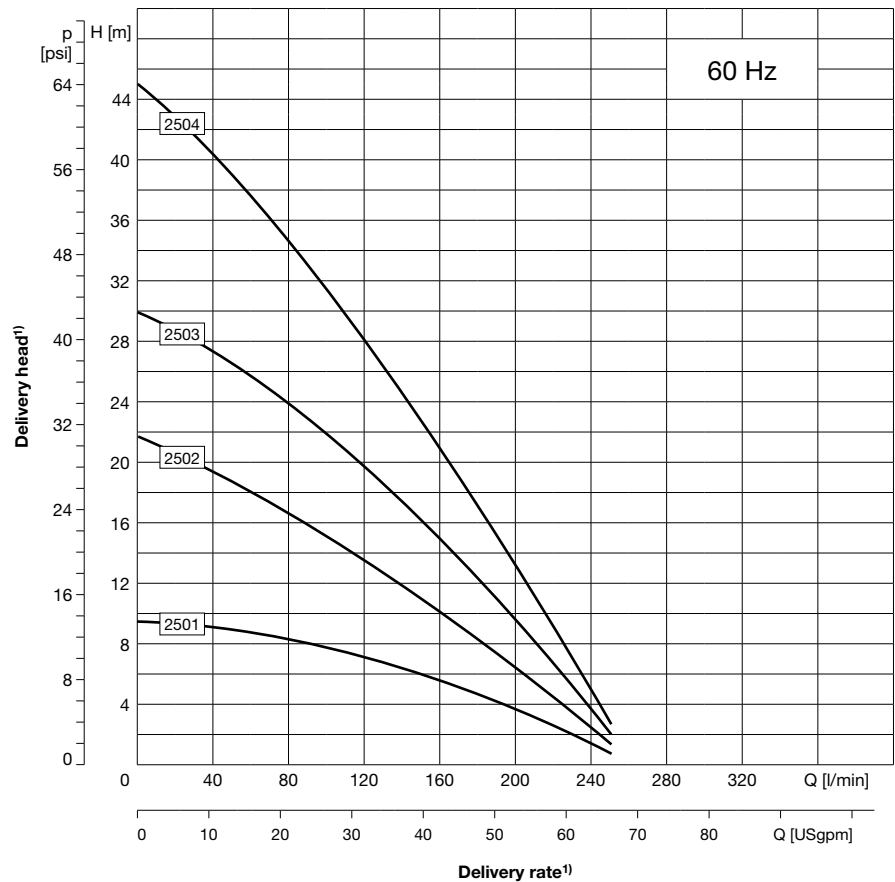

Technical data

Delivery rate Q_{max}	250 l/min
Delivery head H_{max}	45 m
Immersion depth t_{max}	550 mm
Kinematic viscosity	max. 20 mm ² /s
Delivery temperature	
Material "P"	0 °C bis 60 °C
Material "G"	0 °C bis 80 °C
Grain size	max. Ø8 mm
Contamination	max. 1,5% (proportion by weight)
Direction of rotation	anti-clockwise (as viewed looking down on the motor's ventilation side)
Fluids delivered	Various industrial use fluids, emulsions, also with chemical additives, oils, water with corrosion protection additive, water colors, heat transfer oils

Mechanical design

Component	Material
Flange	EN-GJL-200 and steel
Shaft	1.0762
Impeller	POM
Intermediate chamber	EN-GJL-200
Bushes	PTFE graphite
Pumps bottom material "P"	POM
Splash ring material "P"	NBR

Variations

Component	Material
Bottom with extension tube "V"	EN-GJL-200
Impeller material "G"	EN-GJL-200
Bottom standard design "G"	EN-GJL-200
Splash ring material "G"	1.0718

¹⁾ Data for viscosity of ~1 mm²/s at a density of ~1 kg/dm³. Minimum volumetric flow: 5 to 10 % of nominal delivery rate.

PMS 25 – Immersion pumps, sealless 60 Hz, open impellers

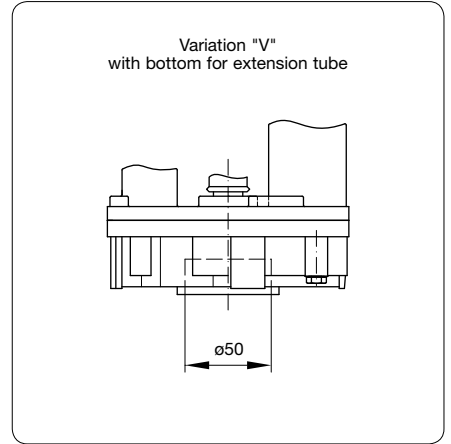
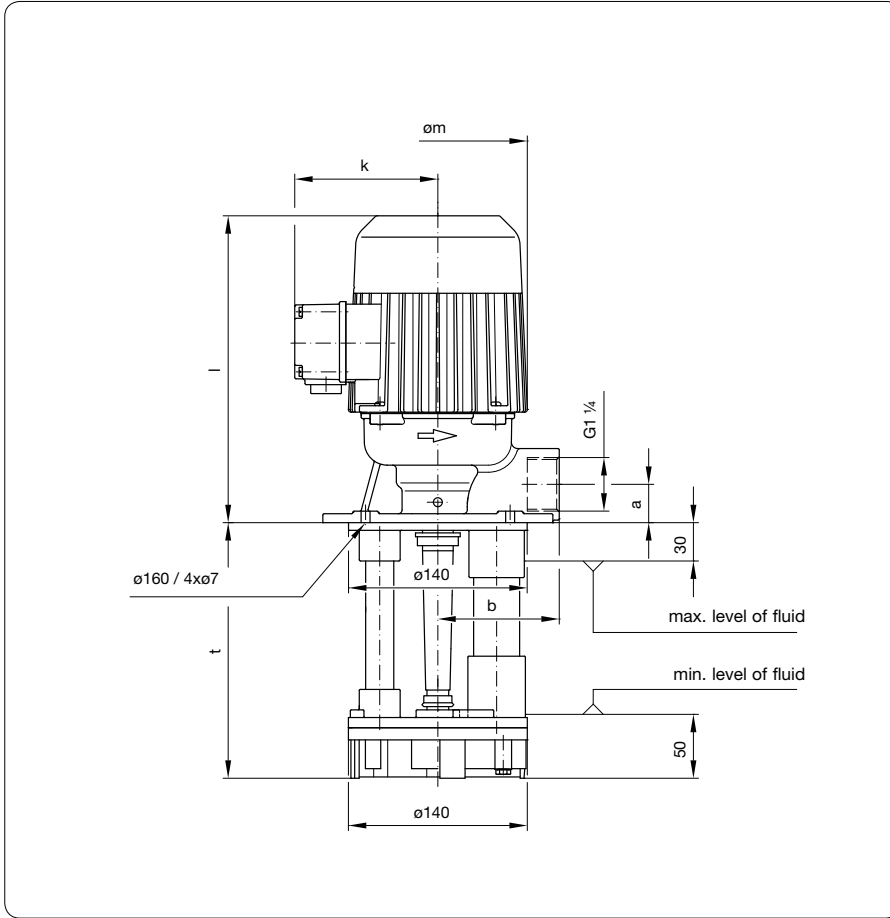

Electrical data, dimensions and weights at 60 Hz

Type of pump			Immer- sion depth t [mm]	Rated motor values				Dimensions [mm]					Weight [kg]	Sonic pressure [dBA]	Pressure port (DIN ISO 228)	
Series	Frame size	Stages		Voltage Δ/Y U [V]	Motor index	Output P _N [kW]	Current Δ/Y I _N [A]	Speed n _N [min ⁻¹]	Øm	k	l	Øa				b
PMS	25	01	170	265/460	F	0,55	1,75/1,01	3446	140	114	241	30	95	13,2 – 16,3	59	G1¼
			200													
			270													
			350													
			440													
		550														
		02	270	265/460	J	1,5	4,33/2,5	3465	176	149	332	32	100	24,0 – 27,5	59	
			310													
			350													
			390													
		03	480	265/460	J	1,5	4,33/2,5	3465	176	149	332	32	100	26,5 – 29,0	65	
			310													
			350													
04	390	265/460	L	3,0	8,65/5,0	3505	196	155	352	32	100	31,0	65			
	430															

PMS 30, 40 – Immersion pumps, sealless 50 Hz, open impellers



Merkmale

- Vertical multistage pump
- Connecting dimensions according to DIN EN 12157
- For delivery of slightly contaminated types of fluids
- Installation directly into the reservoir
- Pressure port is located above the reservoir plate and designed with internal thread G1¼

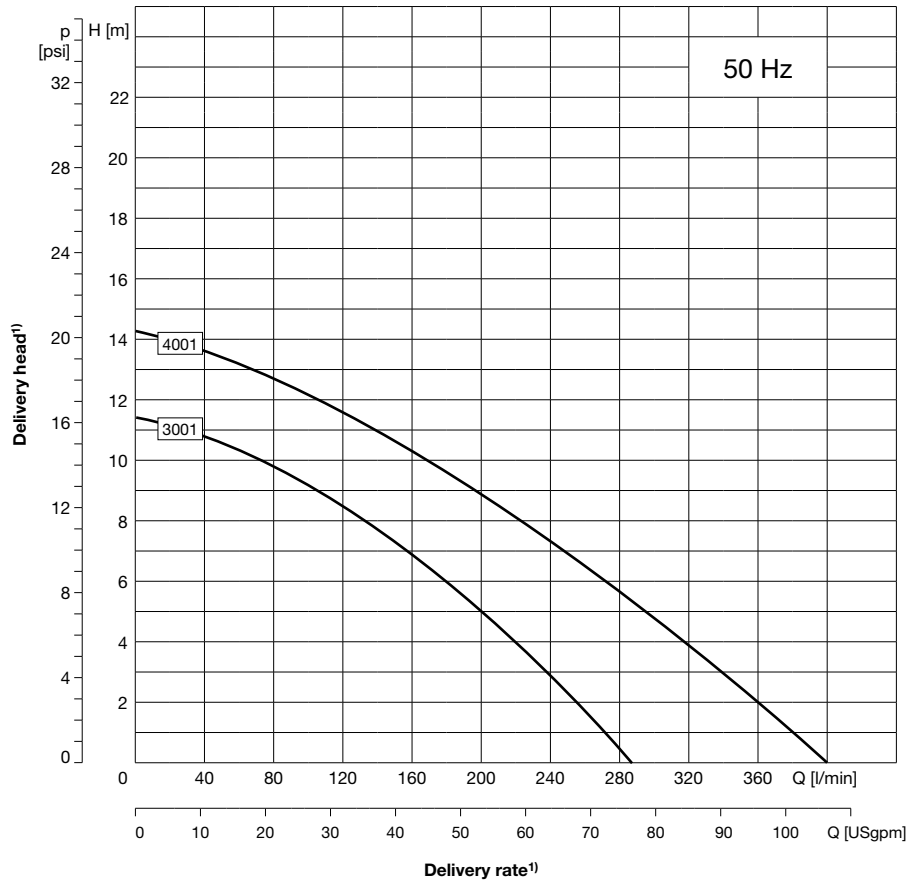

PMS

Technical data

Delivery rate Q_{max}	400 l/min
Delivery head H_{max}	14 m
Immersion depth t_{max}	560 mm
Kinematic viscosity	max. 20 mm ² /s
Delivery temperature	
Material "P"	0 °C bis 60 °C
Material "G"	0 °C bis 80 °C
Grain size	max. Ø8 mm
Contamination	max. 1,5% (proportion by weight)
Direction of rotation	anti-clockwise (as viewed looking down on the motor's ventilation side)
Fluids delivered	Various industrial use fluids, emulsions, also with chemical additives, oils, water with corrosion protection additive, water colors, heat transfer oils

Mechanical design

Component	Material
Flange	EN-GJL-200 and steel
Shaft	1.0762
Impeller	POM
Intermediate chamber	EN-GJL-200
Bushes	PTFE graphite
Pumps bottom material "P"	POM
Splash ring material "P"	NBR

Variations

Component	Material
Bottom with extension tube "V"	EN-GJL-200
Impeller material "G"	EN-GJL-200
Bottom standard design "G"	EN-GJL-200
Splash ring material "G"	1.0718

¹⁾ Data for viscosity of ~1 mm²/s at a density of ~1 kg/dm³. Minimum volumetric flow: 5 to 10 % of nominal delivery rate.

PMS 30, 40 – Immersion pumps, sealless 50 Hz, open impellers

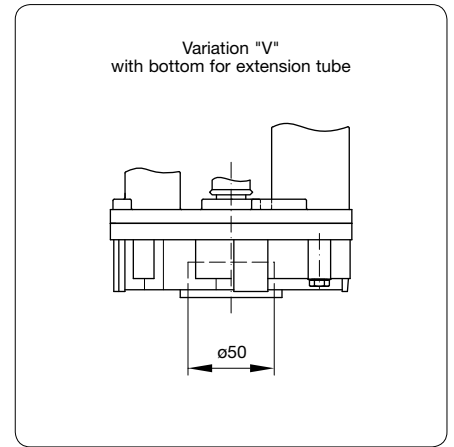
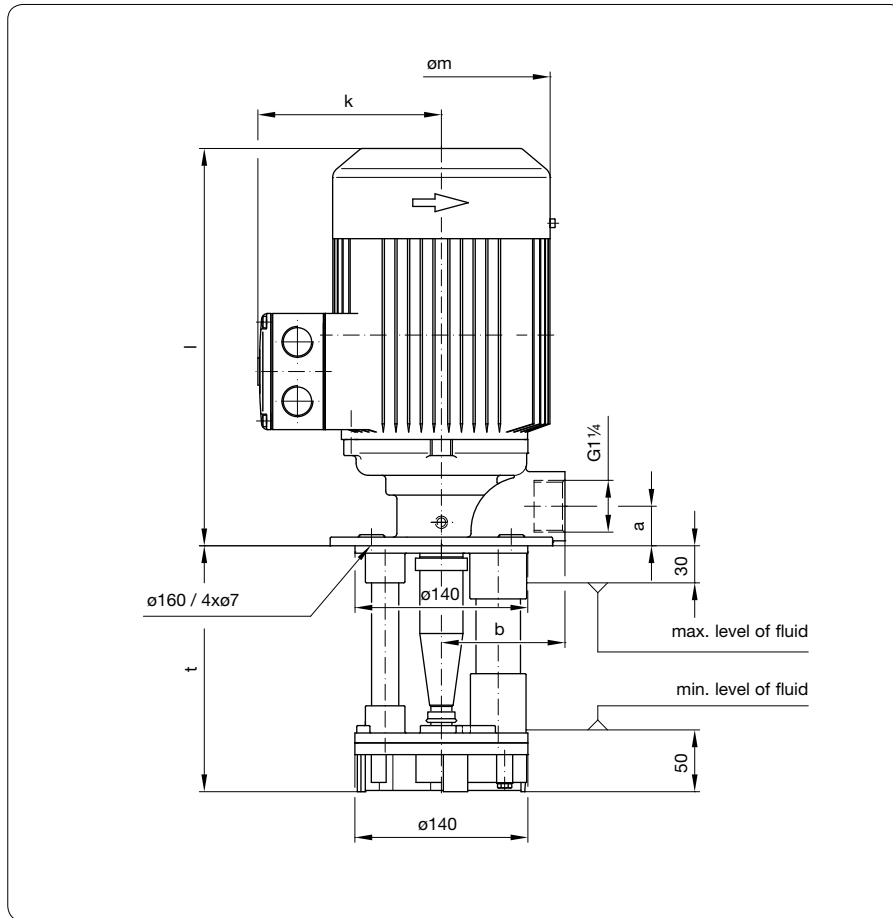

Electrical data, dimensions and weights at 50 Hz

Type of pump			Immer- sion depth t [mm]	Rated motor values					Dimensions [mm]					Weight [kg]	Sonic pressure [dBA]	Pressure port (DIN ISO 228)
Series	Frame size	Stages		Voltage Δ/Y U [V]	Motor index	Output P _N [kW]	Current Δ/Y I _N [A]	Speed n _N [min ⁻¹]	Øm	k	l	Øa	b			
PMS	30	01	170	230/400	G	0,75	2,56/1,48	2870	140	114	241	30	95	13,2 – 16,3	59	G1¼
			200													
			270													
			350													
			440													
	550															
	40	01	210	230/400	J	1,5	4,95/2,86	2850	176	149	332	32	100	23,0 – 26,0	65	
			240													
			280													
			320													
360																
560																

PMS

PMS 30, 40 – Immersion pumps, sealless 60 Hz, open impellers



Merkmale

- Vertical multistage pump
- Connecting dimensions according to DIN EN 12157
- For delivery of slightly contaminated types of fluids
- Installation directly into the reservoir
- Pressure port is located above the reservoir plate and designed with internal thread G1¼

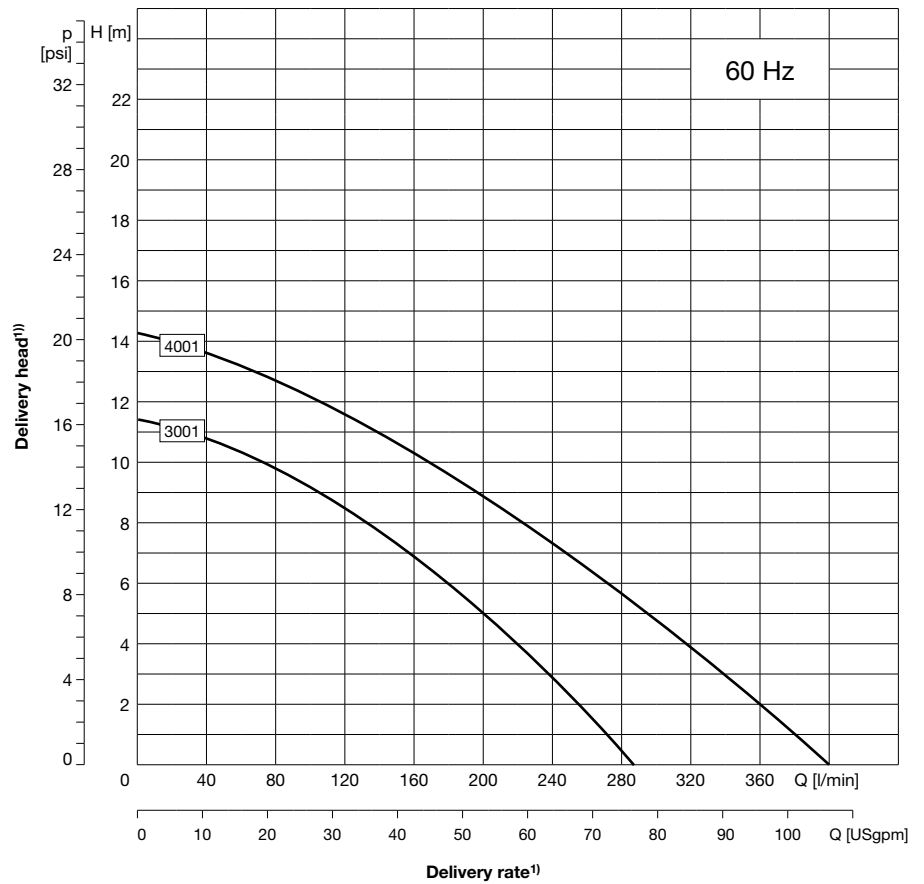

PMS

Technical data

Delivery rate Q _{max}	400 l/min
Delivery head H _{max}	14 m
Immersion depth t _{max}	560 mm
Kinematic viscosity	max. 20 mm ² /s
Delivery temperature	
Material "P"	0 °C bis 60 °C
Material "G"	0 °C bis 80 °C
Grain size	max. Ø8 mm
Contamination	max. 1,5% (proportion by weight)
Direction of rotation	anti-clockwise (as viewed looking down on the motor's ventilation side)
Fluids delivered	Various industrial use fluids, emulsions, also with chemical additives, oils, water with corrosion protection additive, water colors, heat transfer oils

Mechanical design

Component	Material
Flange	EN-GJL-200 and steel
Shaft	1.0762
Impeller	POM
Intermediate chamber	EN-GJL-200
Bushes	PTFE graphite
Pumps bottom material "P"	POM
Splash ring material "P"	NBR

Variations

Component	Material
Bottom with extension tube "V"	EN-GJL-200
Impeller material "G"	EN-GJL-200
Bottom standard design "G"	EN-GJL-200
Splash ring material "G"	1.0718

¹⁾ Data for viscosity of ~1 mm²/s at a density of ~1 kg/dm³. Minimum volumetric flow: 5 to 10 % of nominal delivery rate.

PMS 30, 40 – Immersion pumps, sealless 60 Hz, open impellers

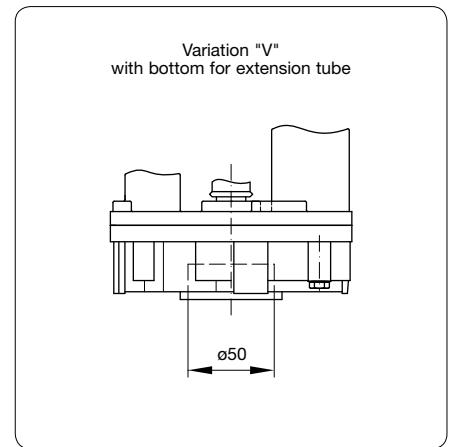
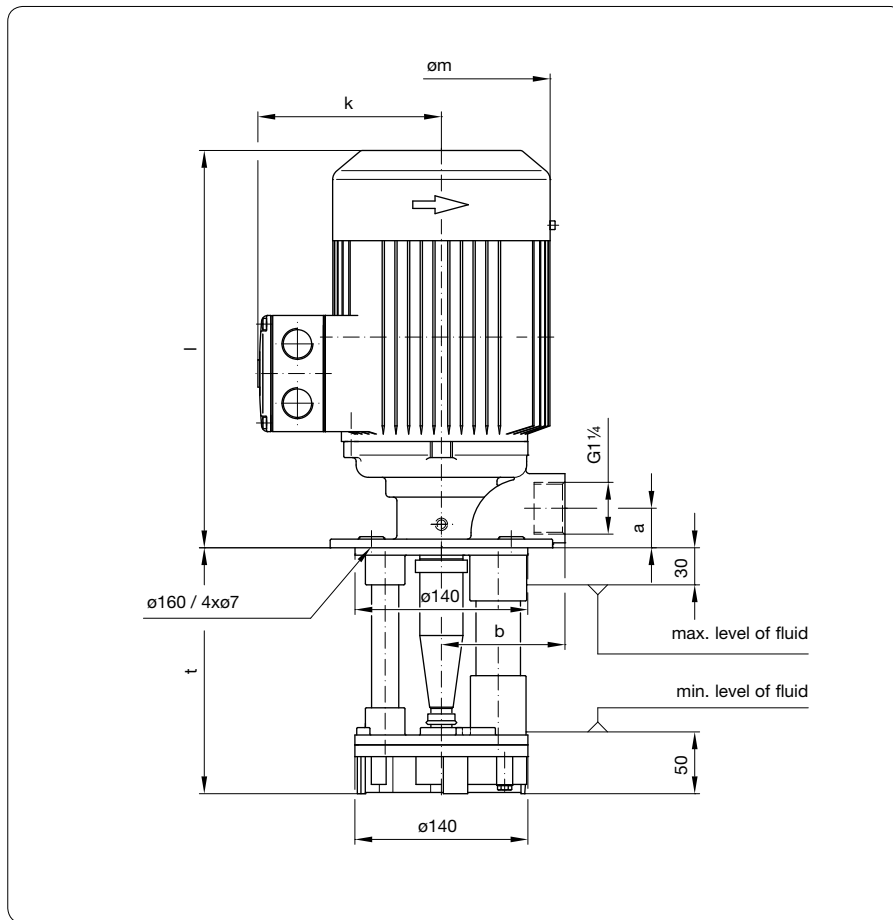

Electrical data, dimensions and weights at 60 Hz

Type of pump			Immer- sion depth t [mm]	Rated motor values					Dimensions [mm]					Weight [kg]	Sonic pressure [dBA]	Pressure port (DIN ISO 228)
Series	Frame size	Stages		Voltage Δ/Y U [V]	Motor index	Output P _N [kW]	Current Δ/Y I _N [A]	Speed n _N [min ⁻¹]	Øm	k	l	Øa	b			
PMS	30	01	170	265/460	G	0,75	2,27/1,31	3410	140	114	241	30	95	13,2 bis 16,3	59	G1¼
			200													
			270													
			350													
			440													
			550													
	40	01	210	265/460	J	1,5	4,33/2,5	3465	176	149	332	32	100	23,0 bis 26,0	65	
			240													
			280													
			320													
			360													
			560													

PMS – Immersion pumps, sealless

Order key

	P	M	S															
Series																		
Frame size																		
To determine the fram size the corresponding characteristics has to be used. 05, 06, 08, 10, 25, 30, 40																		
Stages																		
To determine the desired number of stages the corresponding characteristics has to be used. 01 = 1-stage ... 04 = 4-stages																		
Materials																		
P = plastic (Standard) G = gray cast iron																		
Seal																		
B = gap bush																		
Pump design																		
S = standard design V = bottom for extension tube																		
Immersion depth in mm																		
To determine the desired immersion depth the appropriate table "Electrical data, dimensions and weights" has to be used. 90 = 90 mm ... 560 = 560 mm																		
Motor index																		
To determine the desired motor index the appropriate table "Electrical data, dimensions and weights" has to be used. Example: H = 1,1 kW																		
Power supply																		
01 = 230/400 V at 50 Hz 265/460 V at 60 Hz 05 = Standard für Europa 230/400 V at 50 Hz ... further designs on request																		
Motor design																		
AA = standard up to 0,55 kW (insulation class F, IP 54, 2-pole) BA = standard from 0,75 kW (insulation class F, IP 54, 2-pole, IE2) ... further designs on request																		
Order example: PMS4001GBS280J01BA Series: PMS , Frame size: 40 , 01 -stage, Material: G grey cast iron, Seal: B gap bush, Pump design: S standard design, Immersion depth: 280 mm, Motor index: J 1,5 kW, Power supply: 01 230/400 V at 50 Hz, 265/460 V at 60 Hz, Motor design: BA Standard (IE2)																		

The contents of this publication are the copyright of the publisher and may not be reproduced (even extracts) unless our written permission is granted. Every care has been taken to ensure the accuracy of the information contained in this publication, but no liability can be accepted for any loss or damage whether direct, indirect or consequential, arising out of use of the information contained herein.

SKF Lubrication Systems Germany GmbH
Product department Spandau Pumps

Motzener Strasse 35/37 · 12277 Berlin · Germany
PF 970444 · 12704 Berlin · Germany
Tel. +49 (0)30 72002-0 · Fax +49 (0)30 72002-261
SpandauPumpen@skf.com
www.spandaupumpen.com

This brochure was presented by: